

FEMALE END VIEW

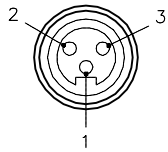

- 1 = GREEN/YELLOW
- 2 = BLACK
- 3 = WHITE



SPECIFICATIONS

HOUSING MATERIAL/PLATING	BRASS/NICKEL
CONTACT CARRIER MATERIAL/COLOR	TPU/BLACK
CONTACT MATERIAL/PLATING	BRASS/GOLD
RATED CURRENT [A]	10.0 A
RATED VOLTAGE [V]	600 V
CONDUCTOR INSULATION MATERIAL	PVC
NUMBER OF CONDUCTORS [AWG]	3x16 AWG
TEMPERATURE RATING	-30°C to +80°C (-22°F to +176°F)
PROTECTION CLASS	MEETS NEMA 1,3,4,6P AND IEC IP67

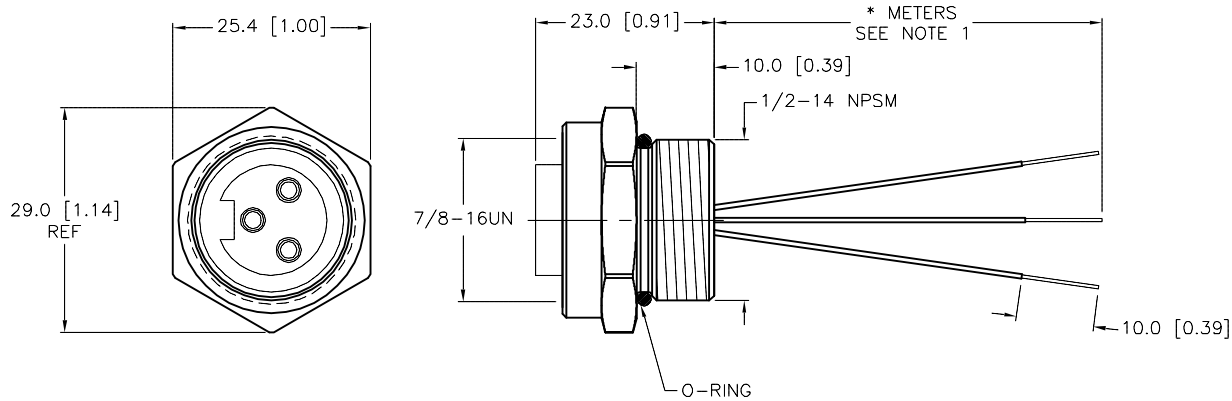

CABLE LENGTH	TOLERANCE *
ALL LENGTHS	+ 4% (OR 50mm) OF LENGTH - 0% (OR 0mm) OF LENGTH WHICHEVER IS GREATER
STRIP LENGTH	TOLERANCE *
0-7mm	±0.5mm
8-29mm	±1.0mm
30-49mm	±2.0mm
50-69mm	±3.0mm
70-100mm	±4.0mm
OVER 100mm	±5.0mm

\* UNLESS OTHERWISE SPECIFIED

NOTES:

- "\*" INDICATES LEAD LENGTH IN METERS. CONTACT TURCK TO ORDER SPECIFIC LENGTHS.
- "/CS10647" DESIGNATES CUSTOM COLOR CODE USING 16 AWG CONDUCTORS.

SOURCE DRAWING - FOR REFERENCE ONLY

RELATED DOCUMENTS 1. 2. 3. 4.	3RD ANGLE PROJECTION 	THIS DRAWING IS CONFIDENTIAL AND THE PROPERTY OF TURCK INC. USE OF THIS DOCUMENT WITHOUT WRITTEN PERMISSION IS PROHIBITED.		3000 CAMPUS DRIVE MINNEAPOLIS, MN 55441 1-800-544-7769 (763) 553-7300 (763) 553-0708 fax www.turck.us	
	MATERIAL SEE SPECIFICATIONS	DRFT RDS DSGN	DATE 05/20/04 SCALE 1=1.0	DESCRIPTION RKF 36-*M/CS10647	
FINISH SEE SPECIFICATIONS	ALL DIMENSIONS DISPLAYED ON THIS DRAWING ARE FOR REFERENCE ONLY	UNIT OF MEASUREMENT <b>MILLIMETER [ INCH ]</b>		IDENTIFICATION NO.	REV B
B UPDATE RATED CURRENT	RDS 12/14/09	29201	DO NOT SCALE THIS DRAWING		
REV DESCRIPTION	BY	DATE	ECO NO.	FILE: 777004385	SHEET 1 OF 1